



GE Additive

Meet the additive
machine developed for
orthopedic implants

Arcam EBM Q10plus

Q10plus

Efficient, cost-effective production of orthopedic implants

The Arcam EBM Q10plus is GE Additive's electron beam melting machine designed specifically for cost-effective production of orthopedic implants. The unique stacking capability of the EBM process allows for maximum utilization of the Q10plus build chamber, which is designed to allow for optimal production of the most common implant types. The Q10plus is particularly ideal for the production of high-volume implants with advanced trabecular structures. Implants can be developed from CT scans of individual patients, allowing for parts customized to each patient's need.

Parts are built in a high-temperature vacuum chamber for a clean, controlled environment. This allows for the processing of reactive materials and helps alleviate porosity for better material properties.

The Q10plus was developed with efficiency in mind. Its compact design means a smaller footprint on your plant floor when compared to other metal additive manufacturing machines.



Q10plus features

- High resolution of built parts
- Unique stacking capability
- Small machine footprint
- Cost-efficient production of orthopedic implants
- Arcam xQam for high-precision autocalibration
- Arcam LayerQam for quality control of each layer

INTEGRATED APPROACH FOR BEST RESULTS

The Q10plus features a powerful, integrated hardware and software system for efficient operation of your EBM machine and better build analysis.

- The Q10plus includes Arcam EBM xQam™ technology for high-precision beam autocalibration, a powerful software platform, and electronics for efficient and accurate beam control.
- Arcam EBM LayerQam™, a camera-based monitoring system, provides for inline part quality verification and comprehensive defect diagnosis. Detailed reports are generated from the data collected by the software after the build is completed. The user is then informed of any defect present and location within the build.

ARCAM EBM BUILD PERFORMANCE ANALYZER (BPA)

Arcam EBM BPA is an analytics software that combines machine behavior, EBM physics and domain system knowledge into an in-depth analysis to give users a quick and easy understanding of performance of each build job.

- Analyzes performance of key machine and process sub-systems, such as vacuum, beam, powder distribution and auxiliary units (such as chiller)
- Quickly assesses severity through simple red-yellow-green indicators
- Diagnoses root cause for failed or aborted builds
- Provides specific recommendations for the user to mitigate the diagnosed issues
- Offers detailed plot views and statistical summaries for further analysis
- Tracks actions taken
- Generates reports and analyzes historic builds

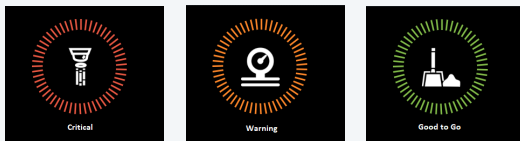

Powder handling equipment

A complete powder handling system to support the additive process, both pre- and post-build:

Powder Recovery Station (PRS)

Recovers unused powder in a closed environment

Vacuum cleaners

Clean the finished build

Sieving station

Filters unused powder to rid of oversized particles

Hopper filling station

Loads sieved powder from barrels into machine hopper

Trolleys

Transport build tank, powder hoppers, and barrels

Arcam EBM Q10plus v2.1

Technical data

Max. build size	200 x 200 x 200 mm (W x D x H)
Max. beam power	3kW
Cathode type	Single crystalline
Minimal part resolution (x-y)	0.75mm (70um layer parameter set/theme)
Performance (door-to-door)*	53.5 cm ³ /h (High density build) 16.6 cm ³ /h (Low density build)
Active cooling	Water-cooled heat sink
Minimum chamber pressure	5 x 10 ⁻⁴ mbar
Typical build atmosphere	4 x 10 ⁻³ mbar (Partial pressure of He)
He consumption, build process	1 liter / hour
He consumption, ventilation	50-75 liters / build
Power supply	3 x 400 V, 32 A, 7kW
Size	2112 x 1134 x 2758 mm (W x D x H)
Weight	1,681 kg
CAD interface	Standard: STL

*High density build refer to a PV1-build, Low density build refer to FAT-build

Machine dimensions

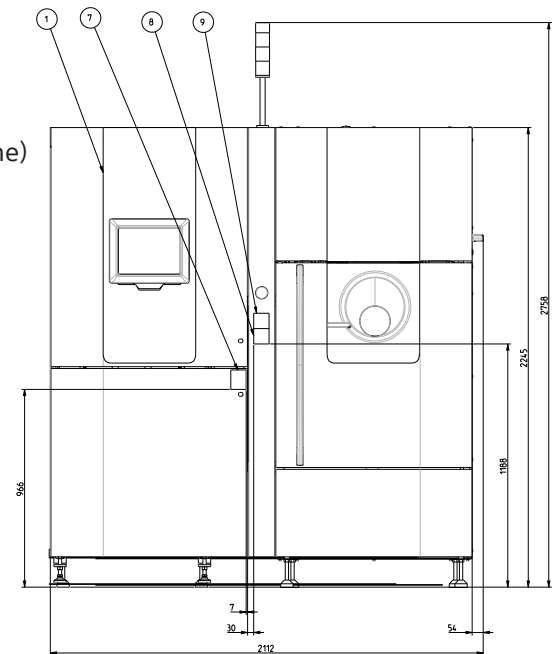

Materials available

- Arcam EBM Ti6Al4V Grade 5, P-Material
- Arcam EBM Ti6Al4V Grade 23, P-Material
- Arcam EBM CoCr, D-Material (Machine v1.0)
- Arcam EBM Ti Grade 2, D-Material (Machine v1.0)
- Arcam EBM Pure Copper, D-Material (Machine v1.0 and v2.0)

